

**ELETTROPOMPE SOMMERSIBILI**  
**SUBMERSIBLE ELECTRIC PUMPS**  
**ELÉCTROBOMBAS SUMERGIBLES**  
**POMPES ÉLECTRIQUES SUBMERSIBLES**

**HYDRO**  
 10M-10T-15M-15T



**Elettropompe sommergibili adatte al prosciugamento di acque chiare e torbide. Possono essere utilizzate come pompe portatili di pronto impiego sia per uso cantiere, pozzetti di scantinati, sia per installazioni fisse con quadro di comando.**



**SPECIFICHE TECNICHE**

- Coperchio: Lega di alluminio anticorrosivo.
- Corpo pompa: Lega di alluminio anticorrosivo.
- Filtro: Lega di alluminio anticorrosivo.
- Piastra d'usura:  
HYDRO 10M-10T-15T acciaio inox AISI 304  
HYDRO 15M- 20M-20T-30T lega di alluminio anticorrosivo con rivestimento in gomma antiusura.
- Girante: Ghisa EN GJL 200 (UNI EN 1561).
- Tenuta meccanica: Carburo di Silicio/Carburo di Silicio (SiC/SiC).
- Alloggio statore: Lega di alluminio EN-AW6060.
- Albero motore: Acciaio INOX AISI 420.
- Bulloneria: Acciaio INOX Classe A2.
- Cavo di alimentazione: 10 metri tipo H07RN-F.  
Versioni monofase HYDRO 10M con cavo 4G1,5mm<sup>2</sup> cassetta porta condensatore e spina SCHUKO (CEE 7/II).
- Versioni monofase HYDRO 15M-20M con cavo 4G2,5mm<sup>2</sup> cassetta porta condensatore e spina SCHUKO (CEE 7/II).
- Versioni trifase con cavo 4G1,5mm<sup>2</sup>.
- Temperatura massima del liquido pompato: +40°C
- pH del liquido pompato: 5÷8.
- Profondità d'immersione massima: 20m.
- Densità del liquido pompato: 1,0 kg/dm<sup>3</sup>.
- Immersione minima per servizio continuo: Vedi disegno.
- Passaggio libero: 6mm.
- Numero massimo di avviamenti ora: 20.
- Livello di pressione acustica generato: <70dB(A).
- Motore elettrico asincrono 2 poli a gabbia di scoiattolo in bagno d'olio.
- Classe d'isolamento F, Grado di protezione IP68.
- Monofase con termoprotettore incorporato ed interruttore a galleggiante.
- Tensione monofase: 230V/50Hz ±6%.
- Tensione trifase: 230V-400V/50Hz ±10%.
- Altre tensioni a richiesta.
- Riempimento con olio bianco alimentare a richiesta.

**HYDRO**  
 20M-20T-30T



**Submersible electric pumps suitable for the lifting of clear and cloudy water. They can be used as portable pumps either in building yards, basement tanks or for fixed installation with control panel.**



**TECHNICAL SPECIFICATIONS**

- Cover: Anticorrosive aluminium alloy.
- Pump body: Anticorrosive aluminium alloy.
- Strainer: Anticorrosive aluminium alloy.
- Wear plate:  
HYDRO 10M-10T-15T Stainless steel AISI 304  
HYDRO 15M- 20M-20T-30T anticorrosive aluminium alloy with rubber coating anti-wear.
- Impeller: cast iron EN GJL 200 (UNI EN 1561).
- Mechanical seal: Silicon Carbide/Silicon Carbide (SiC/SiC).
- Stator housing: Aluminium alloy EN-AW6060.
- Motor shaft: Stainless steel AISI 420.
- Bolts and nuts: Stainless steel Grade A2.
- Feeding cable: 10 meters type H07RN-F.  
Single-phase versions HYDRO 10M with 4G1,5mm<sup>2</sup> cable with capacitor box and SCHUKO plug (CEE 7/II).
- Single-phase versions HYDRO 15M-20M with 4G2,5mm<sup>2</sup> cable with capacitor box and SCHUKO plug (CEE 7/II).
- Three-phase versions with 4G1,5mm<sup>2</sup> cable.
- Max. temperature of the liquid pumped: +40°C.
- pH of the liquid pumped: 5÷8.
- Max. immersion depth: 20m.
- Density of the pumped liquid: 1,0 kg/dm<sup>3</sup>.
- Min. immersion for continuous service: See drawing.
- Free passage: 6mm.
- Max. number starts/hour: 20.
- Acoustic pressure level issued: <70dB(A).
- The electric motor is asynchronous 2 poles with squirrel cage rotor in oil bath.
- Class of insulation F, Protection degree IP68.
- Single-phase built-in overheating protection and float switch.
- Single-phase voltage: 230V/50Hz ±6%.
- Three-phase voltage: 230V-400V/50Hz ±10%.
- Other voltages on request.
- With food grade white oil on request.

2 poli / 2 poles / 2 polos / 2 pôles

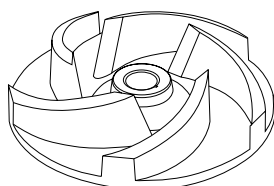

Girante aperta / Open impeller  
 Impulsor abierto / Roue ouverte

# HYDRO 10M-10T-15M-15T-20M-20T-30T

**Bombas eléctricas sumergibles adecuadas para el drenaje de aguas claras y turbias. Pueden utilizarse como bombas portátiles listas para usar tanto para obras de construcción, pozos para sótanos, como para instalaciones fijas con cuadro de mandos.**



## ESPECIFICACIONES TÉCNICAS

- Tapa: Aleación de aluminio anticorrosivo.
- Cuerpo de la bomba: Aleación de aluminio anticorrosivo.
- Filtro: Aleación de aluminio anticorrosivo.
- Plato de usura:  
HYDRO 10M-10T-15T acero inoxidable AISI 304  
HYDRO 15M- 20M-20T-30T aleación de aluminio anticorrosivo en baño de goma contra la usura.
- Impulsor: Fundición EN GJL 200 (UNI EN 1561).
- Sello mecánico: Carburo de Silicio/Carburo de Silicio (SiC/SiC).
- Carcasa del estator: Aleación de aluminio EN-AW6060.
- Eje motor: Acero inoxidable AISI 420.
- Pernos: Acero inoxidable Clase A2.
- Cable de alimentación: 10 metros tipo H07RN-F.  
Versiones monofásicas HYDRO 10M con cable 4G1,5 mm<sup>2</sup> caja lleva condensador y enchufe SCHUKO (CEE 7/II).
- Versiones monofásicas HYDRO 15M-20M con cable 4G2,5 mm<sup>2</sup> caja lleva condensador y enchufe SCHUKO (CEE 7/II).
- Versiones trifásicas con cable 4G1,5mm<sup>2</sup>.
- Temperatura máxima del líquido bombeado: +40°C.
- pH del líquido bombeado: 5÷8.
- Profundidad de inmersión máxima: 20m.
- Densidad del líquido bombeado: 1,0 kg/dm<sup>3</sup>.
- Inmersión mínima para servicio continuo: ver dibujo.
- Paso libre: 6mm.
- Número máximo de arranques por hora: 20.
- Nivel de presión acústica generado: <70dB (A).
- Motor eléctrico asíncrono 2 polos a jaula de ardilla en baño de aceite.
- Clase de aislamiento F, Grado de protección IP68.
- Monofásico con protector térmico integrado e interruptor de flotador.
- Voltaje monofásico: 230V/50Hz ±6%.
- Voltaje trifásico: 230V-400V/50Hz ±10%.
- Otros voltajes según pedido.
- Relleno con aceite blanco para alimentos según pedido.

**Électropompes submersibles indiquées pour le drainage d'eaux claires et troubles. Elles peuvent être employées comme pompes portables prêtes à l'usage soit en chantiers et puisards, soit pour les installations fixes avec tableau de commande.**



## SPÉCIFICATIONS TECHNIQUES

- Couverture: Alliage en aluminium anticorrosif.
- Corps de la pompe: Alliage en aluminium anticorrosif.
- Crépine: Alliage en aluminium anticorrosif.
- Plaque d'usure:  
HYDRO 10M-10T-15T Acier INOX AISI 304  
HYDRO 15M- 20M-20T-30T alliage en aluminium anticorrosif avec revêtement en gomme anti-usure.
- Roue: Fonte EN GJL 200 (UNI EN 1561).
- Étanchéité mécanique: Carbure de Silicium/Carbure de Silicium (SiC/SiC).
- Carcasse stator: Alliage en aluminium EN-AW6060.
- Arbre moteur: Acier INOX AISI 420.
- Visserie: Acier INOX Classe A2.
- Câble d'alimentation: 10 mètres type H07RN-F.  
Versions monophasé HYDRO 10M avec câble 4G1,5mm<sup>2</sup> boîte porte condensateur et fiche SCHUKO (CEE 7/II).
- Versions monophasé HYDRO 15M-20M avec câble 4G2,5mm<sup>2</sup> boîte porte condensateur et fiche SCHUKO (CEE 7/II).
- Version triphasé avec câble 4G1,5mm<sup>2</sup>.
- Temperature max. du liquide pompé: +40°C.
- pH du liquide pompé: 5÷8.
- Profondeur max. d'immersion: 20m.
- Densité du liquide pompé: 1,0 kg/dm<sup>3</sup>.
- Immersion minimum pour le service continu: voir le dessin.
- Passage libre: 6mm.
- Nombre max. de démarrages/heure: 20.
- Niveau de pression acoustique produit: <70dB(A).
- Moteur électrique asynchrone 2 pôles à cage d'écurieuil en bain d'huile.
- Classe d'isolation F, Degré de protection IP68.
- Monophasé avec thermoprotecteur incorporé et flotteur.
- Tension monophasé: 230V/50Hz ±6%.
- Tensions triphasé: 230V-400V/50Hz ±10%.
- Autres tensions sur demande.
- Remplissage avec huile blanche alimentaire sur demande.

**ELETTROPOMPE SOMMERGIBILI**  
**SUBMERSIBLE ELECTRIC PUMPS**  
**ELÉCTROBOMBAS SUMERGIBLES**  
**POMPES ÉLECTRIQUES SUBMERSIBLES**

**50Hz - Dati elettrici / Electrical data / Datos eléctricos / Données électriques**

Serie	P <sub>1</sub> kW	P <sub>2</sub>		V	I <sub>n</sub> A	μF		C m	kg
		kW	HP			μ	V		
10M	1.40	1.00	1.36	230 (1~)	7.20	25	450	10	20.00
10T	1.40	1.00	1.36	230/400 (3~)	3.50/2.00	-	-	10	20.00
15T	1.70	1.10	1.50	230/400 (3~)	5.20/3.00	-	-	10	20.00
15M	2.10	1.40	1.90	230 (1~)	12.00	25	450	10	23.00
20M	2.40	1.80	2.40	230 (1~)	14.00	30	450	10	27.00
20T	2.40	1.80	2.40	230/400 (3~)	8.00/4.60	-	-	10	25.00
30T	2.90	2.20	3.00	230/400 (3~)	8.70/5.00	-	-	10	26.00

**50Hz - Prestazioni / Performance / Rendimento / Performance**

Serie	Q	l/s m <sup>3</sup> /h l/min	0	1.0	2.0	3.0	4.0	5.0	6.0	7.0	8.0	9.0	10.0	11.0	12.0	13.0	14.0	15.0
			0	3.6	7.2	10.8	14.4	18.0	21.6	25.2	28.8	32.4	36.0	39.6	43.2	46.8	50.4	54.0
			0	60	120	180	240	300	360	420	480	540	600	660	720	780	840	900
10M 10T	L n. 1	H (m)	18.0	16.5	15.0	13.5	11.0	8.0	4.5	1.0	-	-	-	-	-	-	-	-
15T	L n. 2		20.0	18.5	17.0	15.5	13.5	11.0	8.5	5.0	-	-	-	-	-	-	-	-
15M	L n. 3		14.3	14.1	13.7	13.1	12.5	11.8	11.0	9.8	8.5	7.0	6.0	4.5	2.8	-	-	-
20M 20T	L n. 4		16.6	16.3	16.1	15.8	15.1	14.2	14.0	12.8	11.8	10.2	9.0	7.0	5.8	4.0	2.0	-
30T	L n. 5		18.5	18.5	18.2	17.8	17.5	16.5	16.0	14.7	13.9	12.0	10.5	9.1	7.5	5.8	4.0	2.0

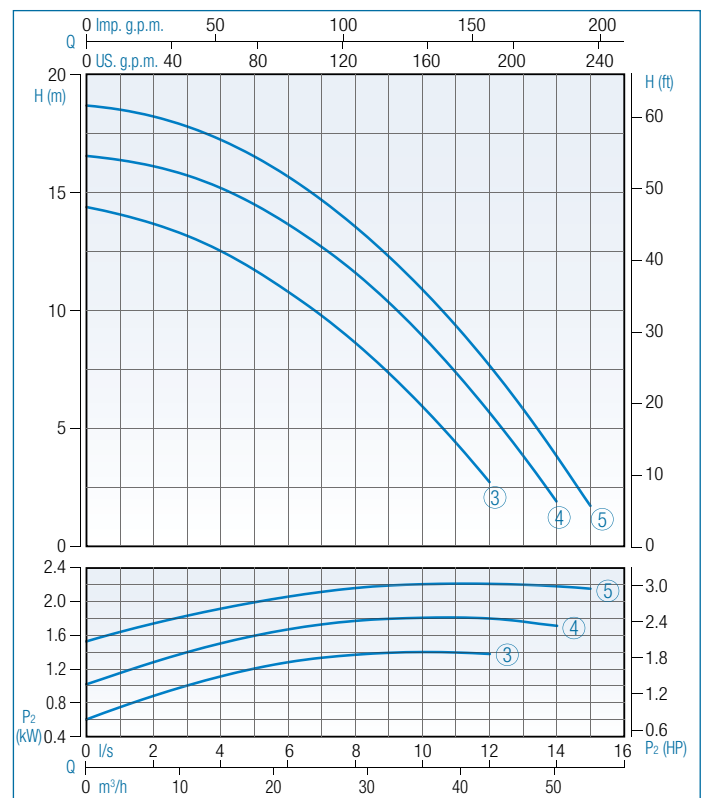
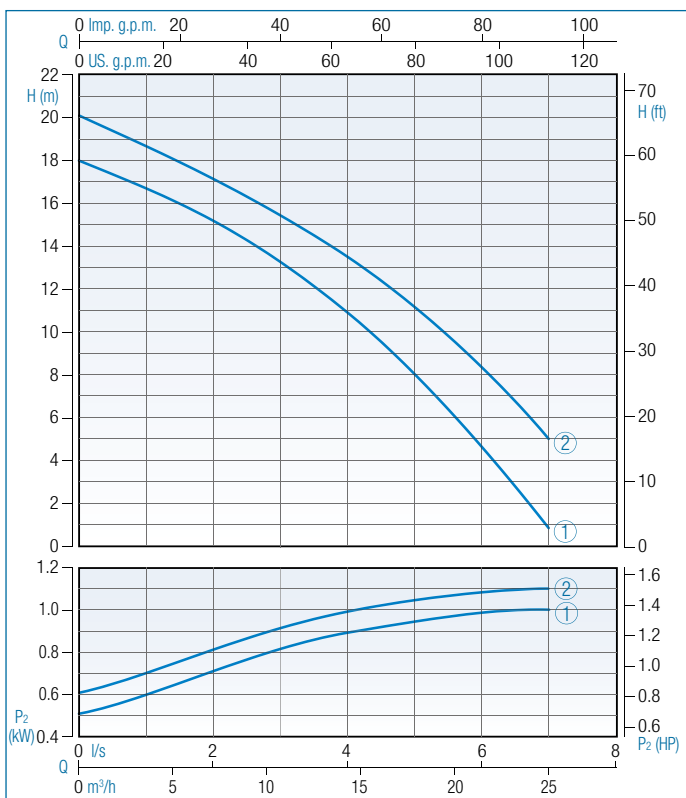

Tolleranza sulle prestazioni secondo norme UNI EN ISO 9906 – Grado 3B / Performance tolerance in according to UNI EN ISO 9906 - Grade 3B  
 Tolerancia de rendimiento según UNI EN ISO 9906 - Grado 3B / Tolérance sur le performance selon les règles UNI EN ISO 9906 - Grade 3B

<b>Serie</b> Tipo Type Tipo Type	<b>P<sub>1</sub></b> Potenza assorbita Power input Potencia absorbida Puissance absorbée	<b>P<sub>2</sub></b> Potenza resa Power output Potencia rendido Puissance rendue	<b>V</b> Tensione Voltage Voltage Voltage	<b>(1 ~)</b> Monofase Single-phase Monofásico Monophasé	<b>(3 ~)</b> Trifase Three-phase Trifásico Triphasé	<b>I<sub>n</sub></b> Corrente nominale Rated current Corriente nominal Courant nominal	<b>μF</b> Condensatore Capacitor Condensador Condensateur
<b>C</b> Cavo Cable Cable Câble	<b>L n.</b> Curva Curve Curva Courbe	<b>Q</b> Portata Flow rate Caudal Débit	<b>H (m)</b> Prevalenza Head Altura man. Hauteur man.	<b>l/s</b> Litri al secondo Liters per second Litros por segundo Litres par seconde	<b>m<sup>3</sup>/h</b> Metri cubi per ora Cubic meters per hour Metros cúbicos por hora Mètres cubes par heure	<b>l/min</b> Litri al minuto Liters per minute Litros por minuto Litres par minute	<b>g.p.m.</b> Galloni per minuto Gallons per minute Galones por minuto Gallons pour minute

Modifiche tecniche senza obbligo di preavviso / Technical modifications without prior notice / Variaciones técnicas sin obligación de aviso previo / Changements techniques sans obligation de préavis

# HYDRO 10M-10T-15M-15T-20M-20T-30T

## Dimensioni di installazione

Installation dimensions

Dimensiones de instalación

Dimensions d'installation

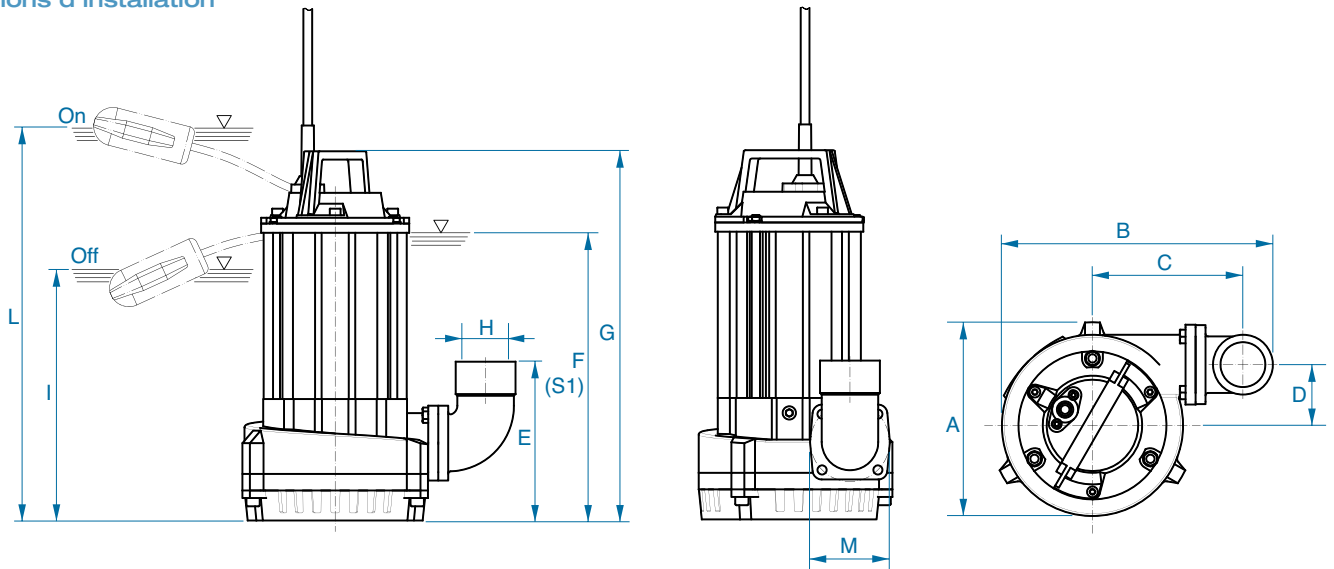

Serie	A	B	C	D	E	F	G	H	I	L	M
10M											
10T	190	290	175	60	162	290	390	G1½			75
15T											
15M											
20M	233	326	180	73	190	345	445	G2			95
20T											
30T											
10M/G	190	290	175	60	162	290	390	G1½	~ 230	~ 440	75
15M/G	233	326	180	73	190	345	485	G2	~ 240	~ 530	95
20M/G											

## Modalità di installazione

Installation mode

Modo de instalación

Mode d'installation

Per impiego di emergenza con attacco per tubo flessibile e per installazione libera nel pozzo di raccolta.

For emergency use with fastening for flexible tube and for free installation in the collecting well.

En caso de emergencia y para libre instalación en el pozo de aspiración con empalme para tubo flexible.

Avec attache pour tube flexible en cas d'urgence et pour une installation libre dans le puits de collecte.

