



MOTORE SOMMERSO 8" RIAVVOLGIBILE



SPECIFICHE TECNICHE

- Motore sommerso 8" riavvolgibile a bagno acqua con aggiunta di glicole propilenico.
- Flangia di accoppiamento 8" in ghisa nichelata.
- Terminale albero motore standard NEMA 8" in Duplex®.
- Accoppiamenti standard NEMA.
- Camicia esterna in AISI 304.
- Gruppo prigioniero, rondelle e dadi in AISI 304.
- Carico assiale: 45000N – 60000N.
- Cuscinetto reggispinta tipo Kingsbury.
- Cavo piatto 4 mt DRINCABLE® (approvato da ACS e WRAS).
- Potenza trifase: 22 kW – 93 kW.
- Avvolgimento standard per temperatura ambiente max. 35°C.
- Avvolgimento con isolamento in PE2/PA per temperature ambiente max. 55°C.
- Velocità minima di raffreddamento: 22 kW – 52 kW = 0,2m/s. 55 kW – 93 kW = 0,5m/s.
- Protezione IP 68.
- Avviamento: S.D. (Y/Δ) con posizione cavi a 90°.
- Tensioni trifase: 380V-415V/60Hz, 460V/60Hz.
- Tolleranza voltaggio: ± 10%.
- Numero di avviamenti per ora: max 20/h.
- Montaggio: verticale/orizzontale.
- Rotazione: oraria/antioraria.
- Sensore di temperatura PT100 da ordinare separatamente.
- Tensioni speciali a richiesta.
- Tenute meccaniche speciali a richiesta.

8" REWINDABLE SUBMERSIBLE MOTOR



TECHNICAL SPECIFICATIONS

- 8" water filled rewindable submersible motor with addition of propylene glycol.
- 8" nichel-plated cast iron coupling flange.
- 8" terminal of motor shaft according to standard NEMA in Duplex®.
- NEMA standard couplings.
- Outer shell in AISI 304.
- Stud-bolt, washers and nuts in AISI 304.
- Axial load: 45000N - 60000N.
- Trust bearing: Kingsbury type.
- Flat cable 4 mt DRINCABLE® (approved by ACS and WRAS).
- Three-phase power: 22 kW – 93 kW.
- Standard winding for ambient temperature max. 35°C.
- Winding with insulation in PE2/PA for ambient temperature max. 55°C.
- Minimum cooling speed: 22 kW – 52 kW = 0,2m/s. 55 kW - 93 kW = 0,5m/s.
- Protection IP68.
- Start: S.D. (Y/Δ) with cables position at 90°.
- Three-phase voltages: 380V-415V/60Hz, 460V/60Hz.
- Voltage tolerance: ± 10%.
- Number of starts per hour: max. 20/h.
- Installation: vertical/horizontal.
- Rotation: clockwise/counterclockwise.
- Temperature sensor PT100 to order separately.
- Special voltages on request.
- Special mechanical seals on request.

MOTOR SUMERGIBLE 8" REBOBINABLE



ESPECIFICACIONES TÉCNICAS

- Motor sumergible de 8" rebobinable en baño de agua con adición de propilenglicol.
- Brida de acoplamiento de 8" en hierro fundido niquelado.
- Terminal de eje motor según estándar NEMA 8" en Duplex®.
- Acoplamientos según estándar NEMA.
- Camisa externa en AISI 304.
- Perno prisionero, arandelas y tuercas en AISI 304.
- Carga axial: 45000N - 60000N.
- Cojinete de apoyo empuje tipo Kingsbury.
- Cable plano de 4 mt DRINCABLE® (aprobado por ACS y WRAS).
- Potencia trifásica: 22 kW – 93 kW.
- Bobinado standard para temperatura ambiente max. 35°C.
- Bobinado con aislamiento en PE2/PA para temperatura ambiente max. 55°C.
- Velocidad mínima de enfriamiento: 22 kW – 52 kW = 0,2 m/s. 55 kW – 93 kW = 0,5 m/s.
- Protección IP68.
- Arranque: S.D. (Y/Δ) con posición de cables a 90°.
- Tensiones trifásica: 380V-415V/60Hz, 460V/60Hz.
- Tolerancia de voltaje: ± 10%.
- Número de arranques por hora: max. 20/h.
- Montaje: vertical/horizontal.
- Rotación: horaria/antihoraria.
- Sensor de temperatura PT100 a pedir por separado.
- Tensiones especiales a pedido.
- Sellos mecánicos especiales a pedido.

MOTEUR IMMÉRGÉ 8" REMBOBINABLE



SPÉCIFICATIONS TECHNIQUES

- Moteur immergé 8" rebobinable en bain d'eau avec addition de propylène glycol.
- Bride d'accouplement 8" en fonte nickelée.
- Terminal de l'arbre moteur selon standard NEMA 8" en Duplex®.
- Accouplements selon standard NEMA.
- Chemise extérieure du moteur en AISI 304.
- Boulon prisonnier, rondelles et écrous en AISI 304.
- Charge axiale: 45000N - 60000N.
- Palier de soutien poussée du type Kingsbury.
- Câble plat 4 mt DRINCABLE® (approuvé par ACS et WRAS).
- Puissance triphasé: 22 kW – 93 kW.
- Bobinage standard pour température ambiante max. 35°C.
- Bobinage avec isolation en PE2/PA pour température ambiante max. 55°C.
- Vitesse de refroidissement minimale: 22 kW – 52 kW = 0,2m/s. 55 kW – 93 kW = 0,5m/s.
- Protection IP68.
- Démarrage: S.D. (Y/Δ) avec position des câbles à 90°.
- Tensions triphasé: 380V-415V/60Hz, 460V/60Hz.
- Tolérance de tension: ± 10%.
- Nombre de démarrages par heure: max. 20/h.
- Montage: vertical/horizontal.
- Rotation: horaire/antihoraire.
- Capteur de température PT100 à ordonner séparément.
- Tensions spéciales sur demande.
- Garnitures mécaniques spéciales sur demande.

MOTORI SOMMERSI RIAVVOLGIBILI AS
AS REWINDABLE SUBMERSIBLE MOTORS
MOTORES SUMERGIBLES REBOBINABLES AS
MOTEURS IMMERGÉS REMBOBINABLES AS

60Hz - Dati elettrici / Electrical data / Datos eléctricos / Données électriques

Trifase / Three-phase / Trifásico / Triphasé

Serie	P ₂		V	I _n A	I _{st} A	RPM	COS φ	n %	S.F.	N	C 400V	±5% (25 °C)			
	kW	HP										Ω Δ	Ω Y / Δ	Ω Δ	Ω Y / Δ
AS8M 22200	22.00	30.00	380 460	53.50 46.50	310 302	3490 3480	0.84 0.86	85 83	1.15	45000	4x16 mm ²				
AS8M 23000	30.00	40.00	380 460	75.00 61.50	400 327	3490 3490	0.85 0.89	84 83	1.15						
AS8M 23700	37.00	50.00	380 460	92.00 75.80	515 410	3500 3490	0.86 0.88	85 84	1.15						
AS8M 24500	45.00	60.00	380 460	110.00 89.60	670 528	3495 3490	0.88 0.87	86 86	1.15						
AS8M 25200	52.00	70.00	380 460	124.00 102.60	770 608	3500 3500	0.87 0.87	86 85	1.15						
AS8M 25500	55.00	75.00	380 460	135.00 109.80	830 659	3500 3510	0.87 0.86	85 86	1.15						
AS8M 26000	60.00	80.00	380 460	145.00 116.50	925 738	3505 3500	0.89 0.88	87 86	1.15						
AS8M 26200	62.00	85.00	380 460	148.00 128.50	950 762	3505 3510	0.88 0.87	88 88	1.15						
AS8MW 26700	67.00	90.00	380 460	151.00 131.60	1040 809	3500 3510	0.89 0.89	88 87	1.15	60000	4x25 mm ²				
AS8MW 27500	75.00	100.00	380 460	175.00 146.00	1150 952	3490 3500	0.89 0.88	88 87	1.15						
AS8MW 28300	83.00	110.00	380 460	194.00 158.80	1350 1092	3490 3500	0.89 0.89	88 87	1.15						
AS8MW 29300	93.00	125.00	380 460	221.00 181.80	1630 1263	3500 3510	0.88 0.87	89 88	1.15						

Serie Tipo Type Tipo Type	P₂ Potenza resa Power output Potencia de salida Puissance de sortie	V Tensione Voltage Tensión Voltage	I_n Corrente nominale Rated current Corriente nominal Courant nominal	I_{st} Corrente di spunto Start current Corriente de arranque Courant de démarrage	cos φ Fattore di potenza Power factor Factor de potencia Facteur de puissance	C Cavo Cable Cable Câble
n Rendimento Efficiency Rendimiento Rendement	S.F. Fattore di servizio Service factor Factor de servicio Facteur de service	N Carico assiale Axial load Carga axial Charge axiale	μF Condensatore Capacitor Condensador Condensateur	Ω (I) Resistenza principale Main resistance Resistencia principal Résistance principale	Ω (II) Resistenza avviamento Start resistance Resistencia de arranque Résistance de démarrage	H Dimensioni Dimensions Dimensions Dimensions

Modifiche tecniche senza obbligo di preavviso / Technical modifications without prior notice / Variaciones técnicas sin obligación de aviso previo / Changements techniques sans obligation de préavis

Dati tecnici / Technical data / Datos técnicos / Données techniques

Serie	P ₂		N	H mm	kg	C			
	kW	HP				mm ² D.O.L.	mm ² S.D.	L=MT	
AS8M 22200	22.00	30.00	45000	1095	179.00	16.00	10.00	4.00	
AS8M 23000	30.00	40.00		1205					
AS8M 23700	37.00	50.00		1245					
AS8M 24500	45.00	60.00		1345					
AS8M 25200	52.00	70.00		1445					
AS8M 25500	55.00	75.00		1445					
AS8M 26000	60.00	80.00		1595					
AS8M 26200	62.00	85.00		1595					
AS8MW 26700	67.00	90.00	60000	1595	266.00	25.00	16.00		
AS8MW 27500	75.00	100.00		1695					
AS8MW 28300	83.00	110.00		1945					
AS8MW 29300	93.00	125.00		1945					321.00
				1945					

Dimensioni cavi

Cables dimensions

Dimensiones de los cables

Dimensions des câbles

Serie	mm ²	In max D.O.L.	In max S.D.	A mm	B mm
4x16	16.0	< 100 A	< 100 A	34.5	11.8
4x25	25.0	100-200 A	100-200 A	42.5	16.0
3x10	10.0	-	< 100 A	23.0	9.9
3x16	16.0	-	100-200 A	28.0	12.0

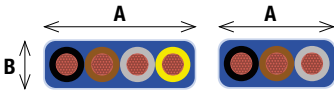

AS8M-D.O.L.

AS8M-S.D.

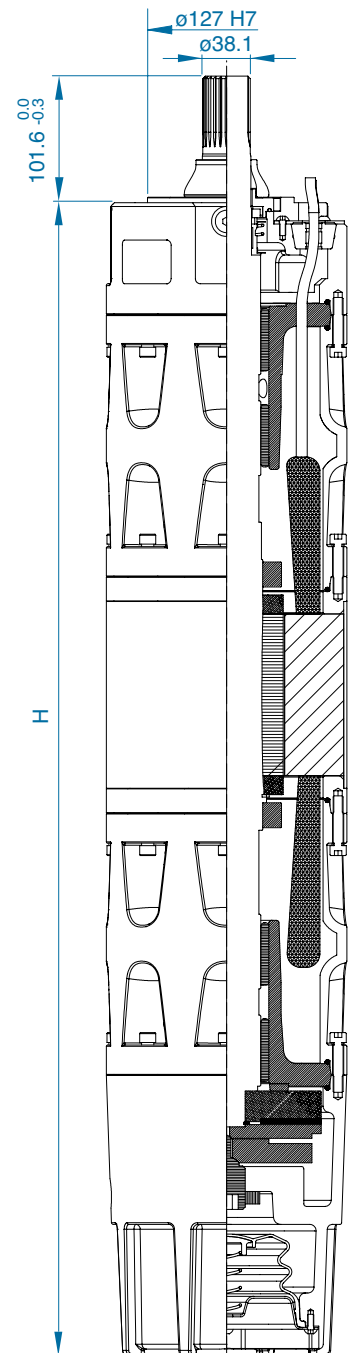
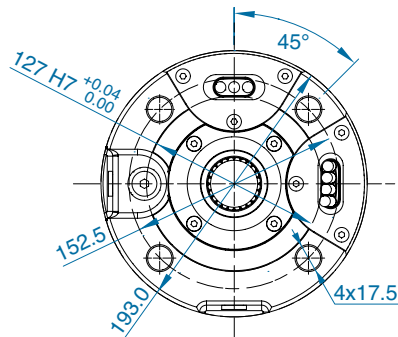
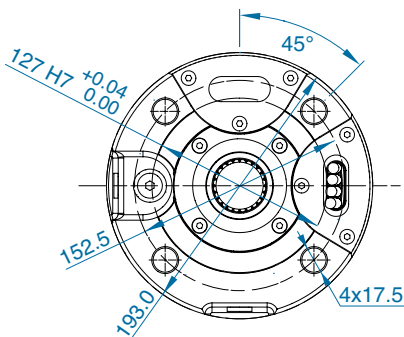

MOTORI SOMMERSI RIAVVOLGIBILI AS

AS REWINDABLE SUBMERSIBLE MOTORS

MOTORES SUMERGIBLES REBOBINABLES AS

MOTEURS IMMERGÉS REMBOBINABLES AS

Lista parti di ricambio

Spare parts list

Lista de repuestos

Liste des pièces de rechange

IT

1	Labirinto di tenuta parasabbia	Sand protection watertight seal labyrinth
2	Vite M5	Screw M5
3	Disco supporto labirinto parasabbia	Sand protection labyrinth bracket plate
4	Anello di tenuta O-Ring	O-Ring watertight seal ring
5	Tenuta meccanica rotante	Rotating mechanical seal
6	Piastrina fermacavo	Cable clamp plate
7	Tassello premicavo	Press cable rawlplug
8	Tassello premicavo cieco / S.D.	Blind press cable rawlplug / S.D.
9	Tappo ottone	Brass plug
10	Supporto superiore lavorato Ghisa	Cast iron wrought upper bracket
11	Supporto distanziale lavorato Ghisa	Cast iron wrought spacer bracket
12	Bronzina	Bush
13	Supporto bronzina lavorato Ghisa	Cast iron wrought bush bracket
14	Spina cilindrica	Cylindrical plug
15	Anello arresto reggispinta	Ring stop of hold up push
16	Vite M5	Screw M5
17	Supporto inferiore lavorato Ghisa	Cast iron wrought lower bracket
18	Vite registro reggispinta M30	Push holder register screw M30
19	Dado esagonale M30	Hexagonal die M30
20	Albero con rotore	Shaft with rotor
21	Anello seeger	Seeger ring
22	Disco reggispinta parte rotante	Rotating part of hold up push plate
23	Reggispinta parte fissa	Hold up push of fixed part
24	Anello seeger	Seeger ring
25	Anello di tenuta O-Ring	O-Ring watertight seal ring
26	Spina cilindrica	Cylindrical plug
27	Cavo di alimentazione	Feeding cable
28	Connettore occhio nudo	Naked eye connector
29	Vite M8	Screw M8
30	Vite M8	Screw M8
31	Rondella M8	Washer M8
32	Membrana di compensazione	Compensation membrane
33	Disco supporto membrana	Membrane bracket plate
34	Molla supporto diaframma	Diaphragm bracket spring
35	Fondello di contenimento membrana	Membrane containment head plate
36	Tappo valvola sfiato	Air hole valve plug
37	Gruppo statore avvolto	Winded stator group

ES

1	Laberinto de estanqueidad en protección de la arena	Labyrinthe d'étanchéité en protection de sable
2	Tornillo M5	Vis M5
3	Disco soporte laberinto en protección de la arena	Disque support labyrinthe en protection de sable
4	Anillo de estanqueidad O-Ring	Anneau d'étanchéité O-Ring
5	Sello mecánico rotativo	Garniture mécanique rotative
6	Placa de sujeción de cable	Plaque serre-câble
7	Taco de prensa de cable	Cheville de serre-câble
8	Taco de prensa de cable ciego / S.D.	Cheville de serre-câble borgne / S.D.
9	Tapón en latón	Bouchon en laiton
10	Soporte superior trabajado en fundición	Support supérieur travaillé en fonte
11	Soporte espaciador trabajado en fundición	Support espaceur travaillé en fonte
12	Buje	Bague
13	Soporte de buje trabajado en fundición	Support du bague travaillé en fonte
14	Enchufe cilíndrica	Prise cylindrique
15	Anillo por parada apoyo empuje	Anneau d'arrêt de soutien poussée
16	Tornillo M5	Vis M5
17	Soporte inferior trabajado en fundición	Support inférieur travaillé en fonte
18	Tornillo de registro de apoyo empuje M30	Vis de registre de soutien poussée M30
19	Dado hexagonal M30	Ecrou hexagonal M30
20	Eje con rotor	Arbre avec rotor
21	Anillo seeger	Anneau seeger
22	Parte rotatoria del disco de apoyo empuje	Partie rotative du disque de soutien poussée
23	Parte fija de apoyo empuje	Partie fixe du soutien poussée
24	Anillo seeger	Anneau seeger
25	Anillo de estanqueidad O-Ring	Anneau d'étanchéité O-Ring
26	Enchufe cilíndrico	Prise cylindrique
27	Cable de alimentación	Câble d'alimentation
28	Conector ojal desnudo	Connecteur à œillet nu
29	Tornillo M8	Vis M8
30	Tornillo M8	Vis M8
31	Arandela M8	Rondelle M8
32	Membrana de compensación	Membrane de compensation
33	Disco soporte membrana	Disque support membrane
34	Muelle soporte diafragma	Ressort de support diaphragme
35	Fondo de contención membrana	Fond de contention membrane
36	Tapón válvula de ventilación	Bouchon valve de ventilation
37	Grupo estator bobinado	Groupe stator bobiné

EN

1	Labirinto di tenuta parasabbia	Sand protection watertight seal labyrinth
2	Vite M5	Screw M5
3	Disco supporto labirinto parasabbia	Sand protection labyrinth bracket plate
4	Anello di tenuta O-Ring	O-Ring watertight seal ring
5	Tenuta meccanica rotante	Rotating mechanical seal
6	Piastrina fermacavo	Cable clamp plate
7	Tassello premicavo	Press cable rawlplug
8	Tassello premicavo cieco / S.D.	Blind press cable rawlplug / S.D.
9	Tappo ottone	Brass plug
10	Supporto superiore lavorato Ghisa	Cast iron wrought upper bracket
11	Supporto distanziale lavorato Ghisa	Cast iron wrought spacer bracket
12	Bronzina	Bush
13	Supporto bronzina lavorato Ghisa	Cast iron wrought bush bracket
14	Spina cilindrica	Cylindrical plug
15	Anello arresto reggispinta	Ring stop of hold up push
16	Vite M5	Screw M5
17	Supporto inferiore lavorato Ghisa	Cast iron wrought lower bracket
18	Vite registro reggispinta M30	Push holder register screw M30
19	Dado esagonale M30	Hexagonal die M30
20	Albero con rotore	Shaft with rotor
21	Anello seeger	Seeger ring
22	Disco reggispinta parte rotante	Rotating part of hold up push plate
23	Reggispinta parte fissa	Hold up push of fixed part
24	Anello seeger	Seeger ring
25	Anello di tenuta O-Ring	O-Ring watertight seal ring
26	Spina cilindrica	Cylindrical plug
27	Cavo di alimentazione	Feeding cable
28	Connettore occhio nudo	Naked eye connector
29	Vite M8	Screw M8
30	Vite M8	Screw M8
31	Rondella M8	Washer M8
32	Membrana di compensazione	Compensation membrane
33	Disco supporto membrana	Membrane bracket plate
34	Molla supporto diaframma	Diaphragm bracket spring
35	Fondello di contenimento membrana	Membrane containment head plate
36	Tappo valvola sfiato	Air hole valve plug
37	Gruppo statore avvolto	Winded stator group

FR

1	Laberinto de estanqueidad en protección de la arena	Labyrinthe d'étanchéité en protection de sable
2	Tornillo M5	Vis M5
3	Disco soporte laberinto en protección de la arena	Disque support labyrinthe en protection de sable
4	Anillo de estanqueidad O-Ring	Anneau d'étanchéité O-Ring
5	Sello mecánico rotativo	Garniture mécanique rotative
6	Placa de sujeción de cable	Plaque serre-câble
7	Taco de prensa de cable	Cheville de serre-câble
8	Taco de prensa de cable ciego / S.D.	Cheville de serre-câble borgne / S.D.
9	Tapón en latón	Bouchon en laiton
10	Soporte superior trabajado en fundición	Support supérieur travaillé en fonte
11	Soporte espaciador trabajado en fundición	Support espaceur travaillé en fonte
12	Buje	Bague
13	Soporte de buje trabajado en fundición	Support du bague travaillé en fonte
14	Enchufe cilíndrica	Prise cylindrique
15	Anillo por parada apoyo empuje	Anneau d'arrêt de soutien poussée
16	Tornillo M5	Vis M5
17	Soporte inferior trabajado en fundición	Support inférieur travaillé en fonte
18	Tornillo de registro de apoyo empuje M30	Vis de registre de soutien poussée M30
19	Dado hexagonal M30	Ecrou hexagonal M30
20	Eje con rotor	Arbre avec rotor
21	Anillo seeger	Anneau seeger
22	Parte rotatoria del disco de apoyo empuje	Partie rotative du disque de soutien poussée
23	Parte fija de apoyo empuje	Partie fixe du soutien poussée
24	Anillo seeger	Anneau seeger
25	Anillo de estanqueidad O-Ring	Anneau d'étanchéité O-Ring
26	Enchufe cilíndrico	Prise cylindrique
27	Cable de alimentación	Câble d'alimentation
28	Conector ojal desnudo	Connecteur à œillet nu
29	Tornillo M8	Vis M8
30	Tornillo M8	Vis M8
31	Arandela M8	Rondelle M8
32	Membrana de compensación	Membrane de compensation
33	Disco soporte membrana	Disque support membrane
34	Muelle soporte diafragma	Ressort de support diaphragme
35	Fondo de contención membrana	Fond de contention membrane
36	Tapón válvula de ventilación	Bouchon valve de ventilation
37	Grupo estator bobinado	Groupe stator bobiné

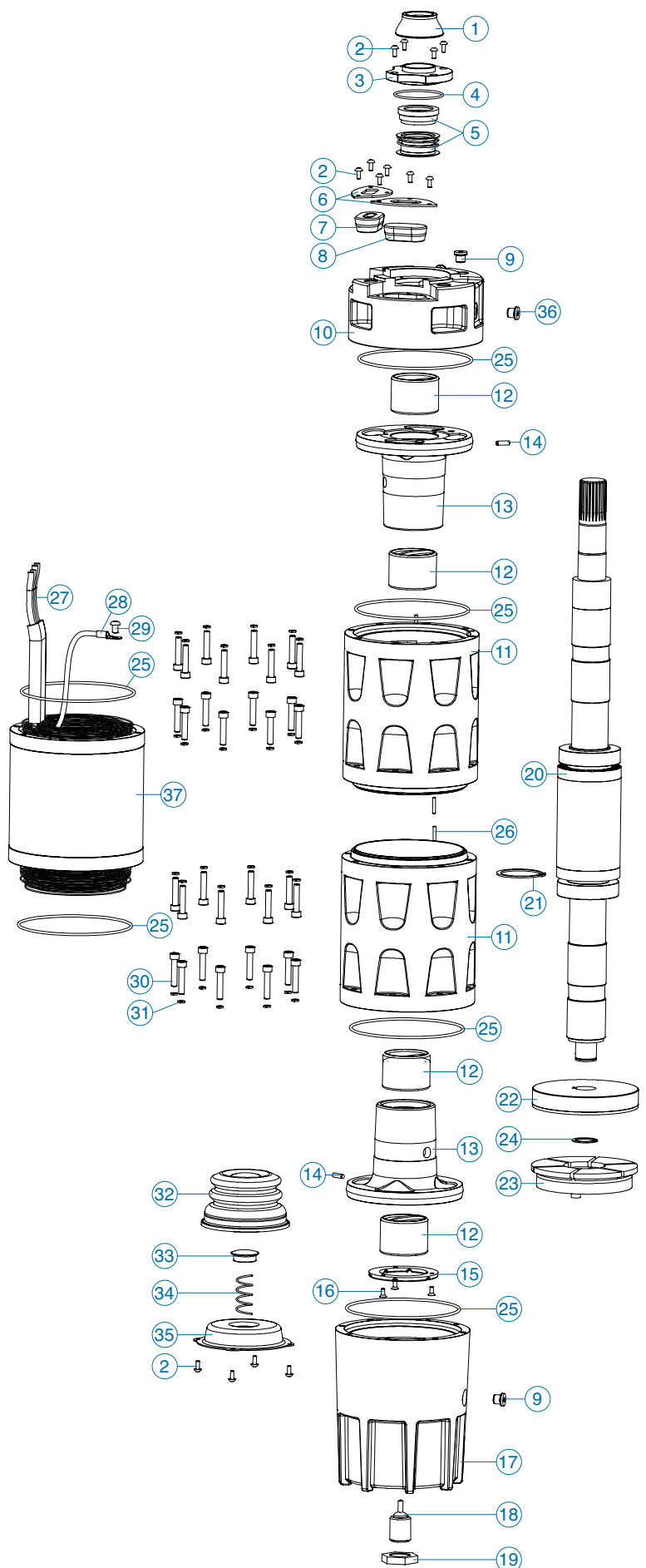

AS8M 8''



AS8M-D.O.L.

AS8M-S.D.

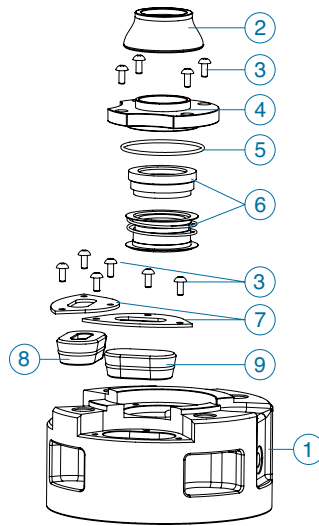

Versioni e materiali Versions and materials Versiones y materiales Versions et matériaux

IT	EN	ES	FR
1 Supporto superiore lavorato Ghisa	Cast iron wrought upper bracket	Soporte superior trabajado en fundición	Support supérieur travaillé en fonte
2 Labirinto di tenuta parasabbia	Sand protection watertight seal labyrinth	Laberinto de estanqueidad en protección de la arena	Labyrinthe d'étanchéité en protection de sable
3 Vite M5	Screw M5	Tornillo M5	Vis M5
4 Disco supporto labirinto parasabbia	Sand protection labyrinth bracket plate	Disco soporte laberinto en protección de la arena	Disque support labyrinthe en protection de sable
5 Anello di tenuta O-Ring	O-Ring watertight seal ring	Anillo de estanqueidad O-Ring	Anneau d'étanchéité O-Ring
6 Tenuta meccanica rotante	Rotating mechanical seal	Sello mecánico rotativo	Garniture mécanique rotative
7 Piastrina fermacavo	Cable clamp plate	Placa de sujeción de cable	Plaque serre-câble
8 Tassello premicavo	Press cable rawlplug	Taco de prensa de cable	Cheville de serre-câble
9 Tassello premicavo cieco / S.D.	Blind press cable rawlplug / S.D.	Taco de prensa de cable ciego / S.D.	Cheville de serre-câble borgne / S.D.

Accessori Accessories Accesorios Accessoires



Tenute Meccaniche in Carbuo di Silicio.
Silicon Carbide mechanical seals.
Sellos mecánicos en Carbuo di Silicio.
Garnitures mécaniques en Carbuo de Silicium.



Sensore di temperatura PT 100.
Temperature sensor PT100.
Captador de temperatura PT100.
Décteur de température PT100.